



Whitepaper: Power over Ethernet- An Overview

Revision 2.0 April 2007

Power over Ethernet: An Overview

INTRODUCTION

Power over Ethernet (PoE) is a standardized technology that allows transmission of data and power over existing Ethernet cables. The technology can greatly simplify the wiring and deployment of networked appliances in a home and office environment.

Ethernet has proliferated in numerous applications such as Voice over IP (VoIP) phones, wireless access points, and network security cameras, to name a few. PoE allows network managers to deploy these systems quickly and efficiently without the burden of creating and maintaining a separate power infrastructure.

Power over Ethernet is standardized by the *IEEE*® 802.3 committee. The technology allows power and data integration while maintaining data integrity and ensuring the safety of the Ethernet network. Currently, the IEEE is working on standardizing the next advancement of PoE, which will allow the delivery of more power and allow applications such as powering laptops, thin clients, video phones, multi-antenna based wireless access points, etc.

PoE products and services are available worldwide; its benefits are the driving factors for the growth of this technology.

BENEFITS OF PoE

PoE brings many benefits for the industry. Some of the most important benefits include:

- **Cost effectiveness:** Since PoE allows transmission of power down the same cable as data, the overall cost of deployment is reduced by not having to pull wires for an AC outlet.
- **Safety:** PoE eliminates the need for high voltage mains, since power is delivered using direct current at 48V.
- **Reliability:** PoE is managed from a centralized UPS. Therefore, in the event of power failure, the PoE system continues to provide power to the PD
- **Mobility:** Since the PD does not need to be near an AC outlet, systems like security cameras and wireless LAN access nodes can be deployed in suitable areas, such as office ceilings.
- **Control:** IT managers can take advantage of having one central location to manage power supplies and data transmission management. They can also monitor and manage power deployment using network management protocols such as SNMP. This leads to improved energy efficiency, lower electrical costs, enhanced troubleshooting capabilities, and improved security. For remote applications, this allows disabling of IP devices for increased network security.
- **Standards based:** System vendors can offer an interoperable solutions at a competitive price to end users, all based on(IEEE®802.3af and IEEE®802.3at

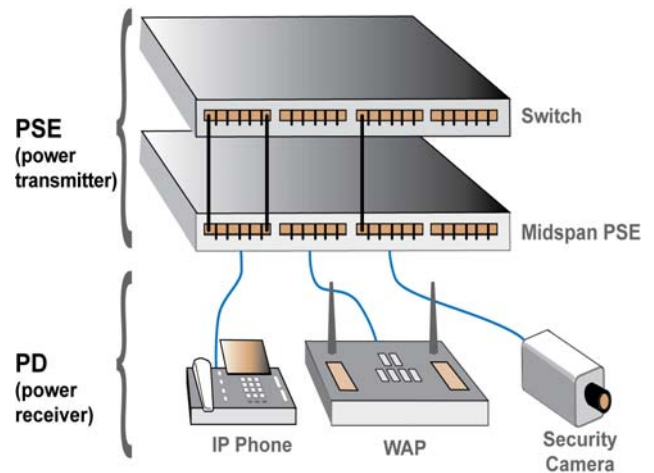

Figure 1: Typical PoE System Arrangement

ELEMENTS OF PoE

As shown in Figure 1, a PoE-based system has two major components, a power transmitter and a power receiver.

1. The power transmitter is called the Power Sourcing Equipment (PSE). There are two types of PSEs. The first is an endspan PSE, where the switch originating the data also provides power. The second is a midspan PSE, which receives data from a non-PoE switch and adds power to the data signal before sending data down the cable. Midspans allow rapid deployment of PoE without having to upgrade the existing non-PoE enabled switches.
2. The power receiver is called a Powered Device (PD). These include network attachments such as Voice over IP phones, wireless LAN access points, and IP enabled security cameras.

TYPICAL PoE POWERED DEVICE OPERATION

IEEE® Std. 802.3af-2003 defines a method for recognizing PDs on the network and supplying different power levels according to power level classes with which each PD is identified. By employing this method, designers can create systems that minimize power usage, allowing more devices to be supported on an Ethernet network.

The PoE method for recognizing a PD and determining the correct power level to allocate uses the following sequence (see Figure 2 and following):

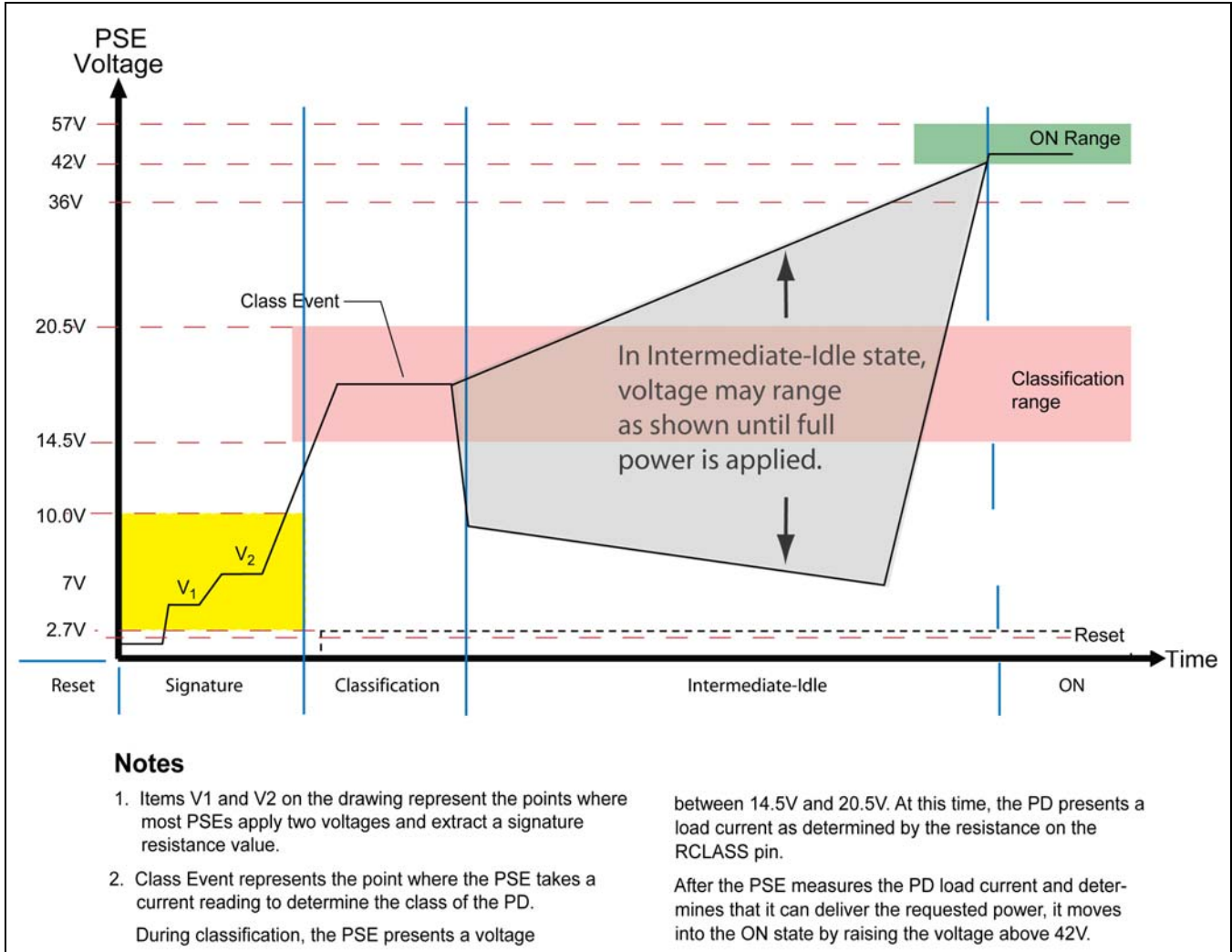

Figure 2: PoE Waveform

- **Signature Detection**, during which the PD is recognized by the PSE.

During signature detection, the PSE applies a specified voltage across the input terminals of the PD and measures the impedance (signature resistance) to determine whether or not a PD is present. If it is present, the PSE obtains a value that its classification circuitry can use to determine the power class the PD belongs to.

To detect a potential PD, the PSE applies a voltage from 2.8V to 10.1V across the input terminals of the PD. The voltage may be of either polarity, so a diode bridge is used to correct for polarity reversal.

The PSE takes two measurements, separated by at least 1V and 2ms of time. The voltage ramp between measurement points will not exceed 0.1V/us. A delta voltage / delta current calculation is then performed; if the detected impedance is above 23.75k Ω and below 26.25k Ω , the PSE will consider a PD to be present. If the impedance is less than 15k Ω or

greater than 33k Ω , a PD will be considered not present and will not receive power. Impedances between these values may or may not indicate the presence of a valid PD. The input capacitance in parallel with the signature impedance must be at least 0.05 μ F and no greater than 0.12 μ F.

- **Classification**, during which the PSE reads the power requirement of the PD. The classification level of a PD identifies how much power the PD requires from the Ethernet line. This permits optimum use of the total power available from the PSE. (Classification is considered optional by IEEE® standard 802.3af-2003.) Five classes of power are defined.

The PSE determines the class of the PD and adjusts its maximum power allocation to the value defined by the detected class. To classify a PD, the PSE presents a voltage between 14.5V and 20.5V to the PD. In response, the PD asserts a load current that corresponds to its power classification. The PSE reads the current level and adjusts the power it delivers.

Power over Ethernet: An Overview

- ON operation, during which the allocated level of power is provided to the PD.
- Reset, wherein power is with drawn from the PD if the applied voltage falls below a specified level.

This sequence occurs as progressively rising voltage levels from the PSE are detected.

To design PoE systems according to the PoE standards, designers have the following constraints:

Requirement	Value
Maximum power to PD	12.95W
Voltage from PSE	44-57V
Maximum operating current	350mA
Line resistance	20Ω
Resulting voltage drop due to series line resistance	7V
Resulting low voltage at PD interface	37V

POWER FEED ALTERNATIVES

Figure 3 illustrates the two power feed options allowed in the 802.3af standard. In Alternative A, a PSE powers the end station by feeding power along the twisted-pair cable used for the 10/100 Ethernet signal via the center taps of Ethernet transformers. On the line side of the transformers, PD power is delivered through pins 1 and 2 and returned through

pins 3 and 6. In Alternative B, a PSE powers the end station by feeding power directly through the twisted cable pairs not used for 10/100 data transmission. Power is delivered through pins 4, 5, 7, and 8 without transformers.

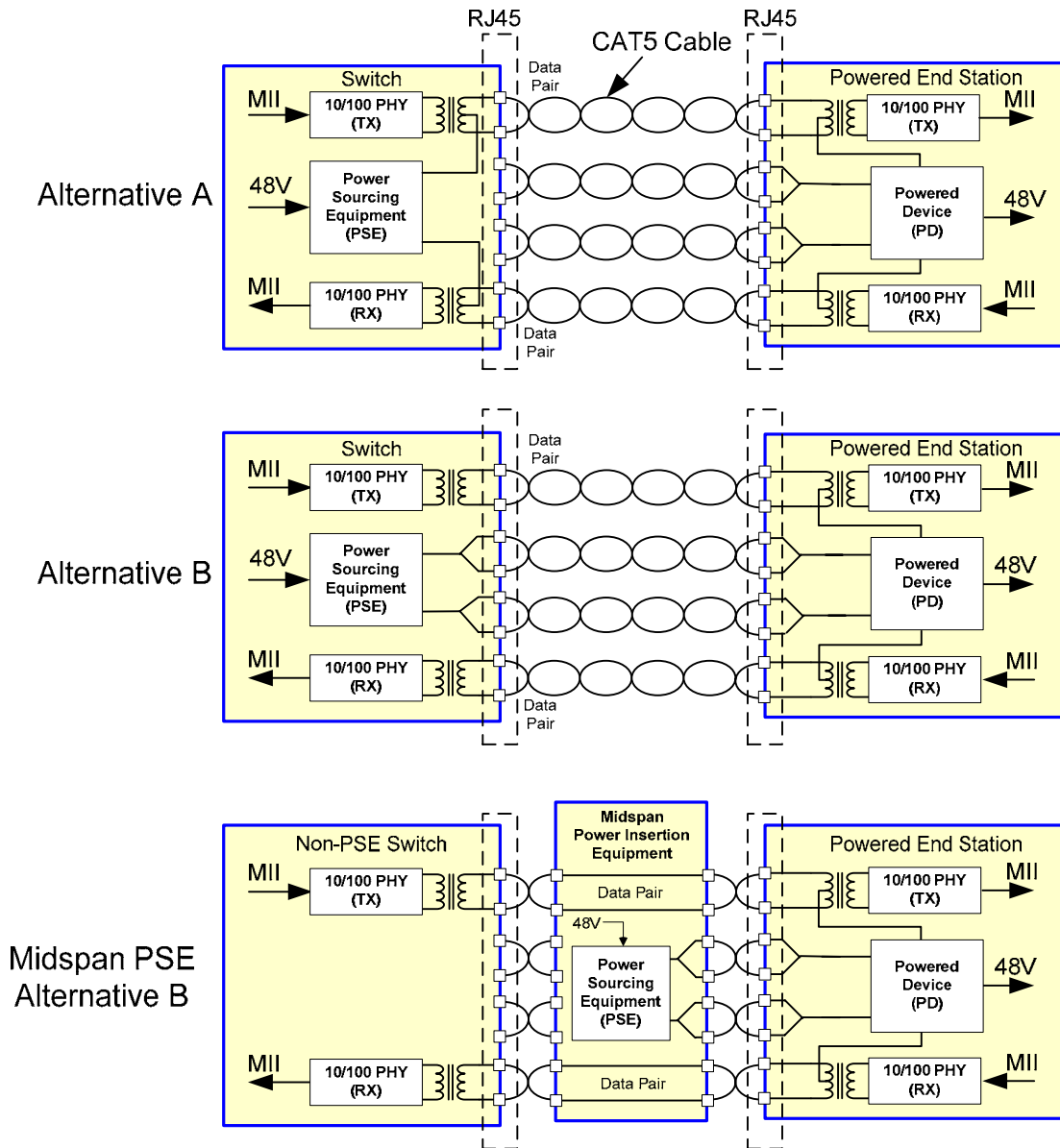

Figure 3: 10/100 Power Feed Alternatives

The IEEE® Std. 802.3af-2003 is intended to be fully compliant with all existing non-line powered Ethernet systems. As a result, the PSE is required to detect via a well-defined procedure whether or not the connected device is PD compliant and

classify the amount of needed power prior to applying power to the system. Maximum allowed voltage is 57V to stay within the SELV (Safety Extra Low Voltage) limits.

Power over Ethernet: An Overview

THE NEXT GENERATION STANDARD

In 2005, the IEEE formulated a new group that is driving the next standard for PoE. The standard will be called the IEEE® 802.3at (also known as PoEPlus) the objectives of this standard are as follows:

- PoEPlus will enhance 802.3af and work within its framework – there will be no new clause.
- The target infrastructure for PoEPlus will be ISO/IEC 11801-1995 Class D or higher systems. Further we will not cause a safety issue for a legacy installation conformant to ISO/IEC 60950.
- IEEE STD 802.3 will continue to comply with the limited power source and SELV requirements as defined in ISO/IEC 60950.
- The PoEPlus PSE shall operate in modes compatible with the existing requirements of IEEE® STD 802.3af as well as enhanced modes.
- The enhanced standard will provide the maximum power to the PD as allowed within practical limits.
- PoEPlus shall support a minimum of 30Watts of power at the PD PI (power interface).
- PoEPlus PDs, which require a PoEPlus PSE, shall provide the user an active indication when connected to a legacy 802.3af PSE. This indication is in addition to any optional management indication that may be provided.
- The standard shall not preclude the ability to meet FCC / CISPR / EN Class A, Class B, Performance Criteria A and Performance Criteria B with data for all supported PHYs.
- Research potential extension of power classification to support PoEPlus modes.
- PoEPlus will vigorously pursue supporting the operation of midspan PSEs for 1000BASE-T.
- Research the operations of midspan and endpoint PSEs for 10GBASE-T including providing cable heating data for evaluation by IEEE®P802.3an.

- That IEEE®802.3af power over the MDI isolation requirements be revisited as part of the PoEPlus work.
- PoEPlus PDs within the power range of 802.3af will work properly with 802.3af PSEs.
- PD Operation based on PSE.

	IEEE Std 802.3af PSE	PoEP PSE
IEEE Std 802.3af PD	Operates	Operates
PoE PD <12.95W	Operates	Operates ^{Note 1}
PoE PD >12.95W	PD shall provide user active indication	Operates ^{Note 1}

Note 1: Operates with extended power classification

With 802.3at, a complete new class of devices will be powered through network interface. These include RFID terminals, and pan-tilt-zoom security cameras, 802.11n wireless access point, laptops, thin-client computers and point of sale terminals, to name a few.

CONCLUSION

Power over Ethernet (PoE) is an exciting new technology that allows users to take advantage of cost and power savings, flexibility, reliability, enhanced security, and standards-based systems in enterprise, industrial, and residential segments. With the upcoming 802.3at standard, more power will be available to the end appliance. This new capability is enabling new applications which will continue to fuel growth of the PoE market.

CONTACT INFORMATION

Akros Silicon Inc.
275 Turn Pike Drive
Folsom, CA. 95630
USA

Tel: (916) 351 8100

Fax: (916) 351 8102

Email inquiries: marcom@akrossilicon.com

Website: www.akrossilicon.com

IMPORTANT NOTICES

LEGAL NOTICE

Copyright © 2007 Akros Silicon™ . All rights reserved.

Akros Silicon™ assumes no responsibility or liability for information contained in this document. Akros reserves the right to make corrections, modifications, enhancements, improvements, and other changes to its products and services at any time and to discontinue any product or services without notice. The information contained herein is believed to be accurate and reliable at the time of printing.

LIFE AND SAFETY POLICY

Akros' products are not authorized for use as critical components in life support systems for surgical implant into the body, or other applications intended to support or sustain life or any other applications whereby a failure of the Akros product could create a situation where personal injury, death or damage to persons, systems, data or business may occur.