



Product Brief: JN5148

ZigBee PRO and IEEE802.15.4 Wireless Microcontroller

Overview

The JN5148 is an ultra low power, high performance wireless microcontroller targeted at ZigBee PRO networking applications. The device features an enhanced 32-bit RISC processor offering high coding efficiency through variable width instructions, a multi-stage instruction pipeline and low power operation with programmable clock speeds. It also includes a 2.4GHz IEEE802.15.4 compliant transceiver, 128kB of ROM, 128kB of RAM, and a rich mix of analogue and digital peripherals. The large memory footprint allows the device to run both the ZigBee PRO stack and an embedded application or in a co-processor mode. The operating current is below 18mA, allowing operation direct from a coin cell.

Enhanced peripherals include low power pulse counters running in sleep mode designed for pulse counting in AMR applications and a unique Time of Flight ranging engine, allowing accurate location services to be implemented on wireless sensor networks. It also includes a 4-wire I²S audio interface to interface directly to mainstream audio CODECs as well as conventional MCU peripherals.

Block Diagram

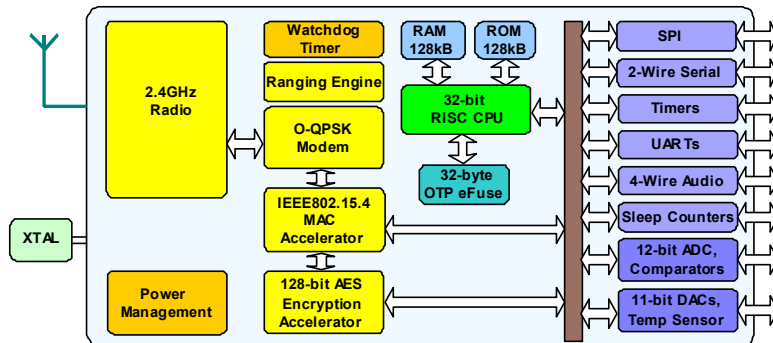

Benefits

- Single chip integrates transceiver and microcontroller for wireless sensor networks
- Large memory footprint to run ZigBee PRO together with an application
- Very low current solution for long battery life
- Highly featured 32-bit RISC CPU for high performance and low power
- System BOM is low in component count and cost
- Extensive user peripherals

Applications

- Robust and secure low power wireless applications
- ZigBee PRO networks
- Utilities metering (e.g. AMR)
- Home and commercial building automation
- Location Aware services - eg Asset Tracking
- Industrial systems
- Telemetry
- Remote Control
- Toys and gaming peripherals

Features: Transceiver

- 2.4GHz IEEE802.15.4 compliant
- Time of Flight ranging engine
- 128-bit AES security processor
- MAC accelerator with packet formatting, CRCs, address check, auto-acks, timers
- 500 & 667kbps data rate modes
- Integrated sleep oscillator for low power
- On chip power regulation for 2.0V to 3.6V battery operation
- Deep sleep current 100nA
- Sleep current with active sleep timer 1.25µA
- <\$0.50 external component cost
- Rx current 17.5mA
- Tx current 15mA
- Receiver sensitivity -95dBm
- Transmit power 2.5dBm

Features: Microcontroller

- 32-bit RISC CPU, 4 to 32MHz clock speed
- Low power operation
- Variable instruction width for high coding efficiency
- Multi-stage instruction pipeline
- 128kB ROM and 128kB RAM for bootloaded program code
- JTAG debug interface
- 4-input 12-bit ADC, 2 12-bit DACs, 2 comparators
- 3 application timer/counters
- 2 UARTs
- SPI port with 5 selects
- 2-wire serial interface
- 4-wire digital audio interface
- Watchdog timer and Power-on-Reset circuit
- Up to 21 DIO

Industrial temp (-40°C to +85°C)

8x8mm 56-lead Sawn QFN

Lead-free and RoHS compliant

