



# Tsi382™ Evaluation Board Product Brief

## Board Features

- Single x1 lane, 2.5 Gbps PCIe extended height riser card
- Fully compliant with PCI Express Specification (Revision 1.1)
- Four 32-bit, 25–66 MHz, PCI slots
- Serial EEPROM that can be programmed with optimized settings for the Tsi382
- PCI power supported through system or external ATX supply
- 3.3V/Universal PCI card support
- Optional 5V PCI card support
- Optional on-board PCIe reference clock
- Optional on-board PCI bus clock
- Manual and auto-detect PCI bus clock frequency
- Over current protection

## Board Benefits

- Evaluate features and functionalities of the Tsi382
- Test and tune performance of the Tsi382 in desired application
- Prototype hardware development before finalizing application design

## Board Overview

The IDT Tsi382 evaluation board is ideal for evaluating and prototyping the Tsi382 PCIe-to-PCI bridge. The Tsi382 evaluation board is an extended height x1 PCIe card that is designed to fit into a standard PCIe slot on a PC motherboard, or interconnect with other cards equipped with a standard PCIe connector.

The evaluation board uses the Tsi382 to bridge between x1 PCIe on the card edge to four 32-bit PCI slots on the board.

Developers can plug 32-bit 3.3V or Universal PCI adapter cards into any or all of the four slots. The evaluation board can adapt the cards to PCIe allowing developers to test the design's behavior on the PCI card when bridging to PCIe. For example, a PC card developer can take an existing PCI adapter card and use the evaluation board to quickly prototype a new design with a PCIe interface.

To evaluate the feature set of the Tsi382, IDT also offers an easy-to-use Microsoft Windows based tool called "TsiView." This tool provides read and write access to an IDT "Tsi" PCIe device's register settings. In addition, it can be used to program an on-board, serial EEPROM device with register settings that have been optimized by TsiView.

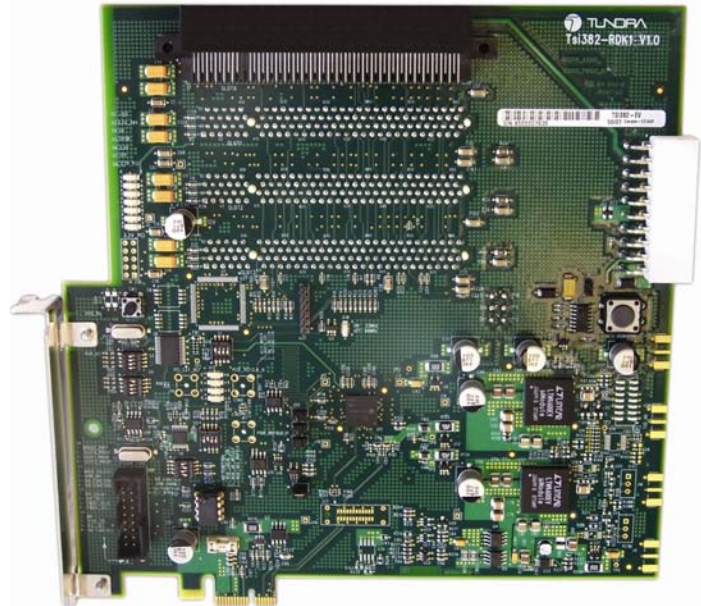

Figure 1 Tsi382 Evaluation Board

## Tsi382 Overview

The Tsi382 is a high performance bridge that connects a single lane PCIe interface to the PCI bus 3.0 standard.

The device's PCIe Interface is compliant with the *PCI Express Specification (Revision 1.1)*. Its 32-bit PCI Interface can operate up to 66 MHz in PCI mode, and offer designers extensive flexibility by supporting three types of addressing modes: transparent, opaque, and non-transparent.

## Tsi382 Key Features

### General

- PCI Express to PCI bridge
- Fully compliant with *PCI Express Specification (Revision 1.1)*
- Transparent, Non-transparent and Opaque modes
- Efficient queuing and buffering for low latency and high throughput

### PCIe

- x1 lane PCIe Interface
- Advanced error reporting capability
- End-to-end CRC check and generation
- Up to four outstanding memory reads

PCI

- 32/64-bit addressing and 32-bit data
- Operates at 25, 33, 50, and 66 MHz
- Up to eight outstanding memory reads
- Four external PCI masters supported through internal arbiter
- PCI clock outputs for up to four devices
- 3.3V PCI I/Os, 5V tolerant

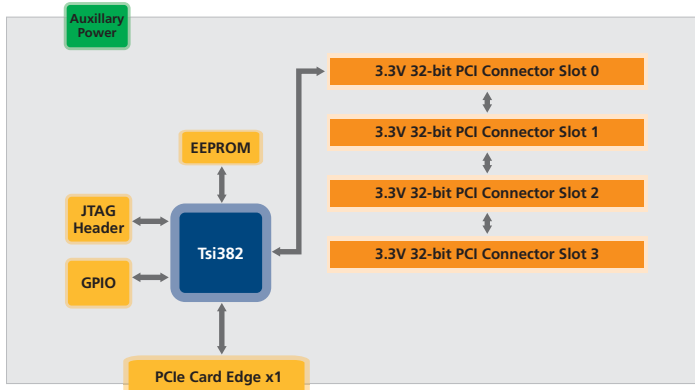

Figure 2 Tsi382 Evaluation Board – Block Diagram

NOT AN OFFER FOR SALE

The information presented herein is subject to a Non-Disclosure Agreement and is for planning purposes only. Nothing contained in this presentation, whether verbal or written, is intended as, or shall have the effect of, a sale or an offer for sale that creates a contractual power of acceptance.



**CORPORATE HEADQUARTERS**  
6024 Silver Creek Valley Road  
San Jose, CA 95138

**for SALES:**  
800-345-7015 or 408-284-8200  
fax: 408-284-2775  
www.idt.com

**for Tech Support:**  
email: [ssdhelp@idt.com](mailto:ssdhelp@idt.com)  
phone: 408-284-8208  
document: 60E2010\_FB001\_02